

STUDENT PORTFOLIO

CO2 DRAGSTER

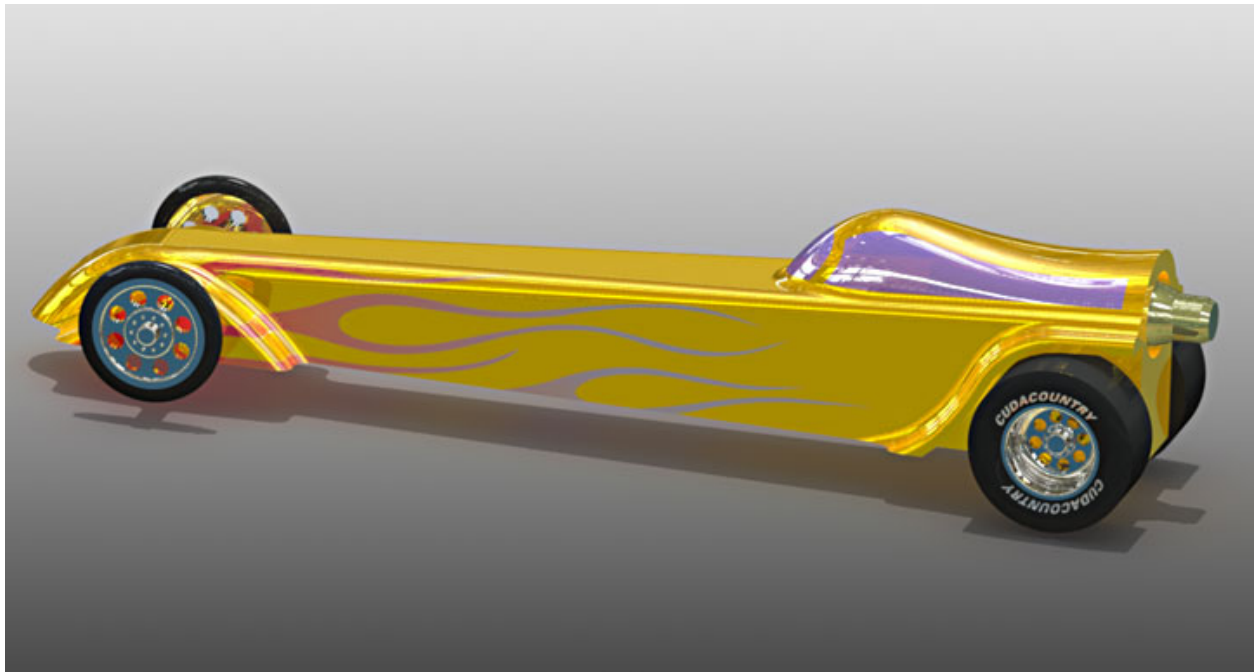

Student Engineer Name: _____

Hour: _____

Date: _____



Need for Speed / CO2 Dragsters



A) Analysing Needs, Problems and Opportunities

Problem:

In the space below discuss, what is the problem that needs to be solved.

Design Brief:

Rewrite the design brief in the space provided.

Design Parameters:

List the different parts which will make up your CO2 dragster.

- a)
- b)
- c)
- d)
- e)
- f)

Establishing Criteria for Success:

In the space below describe four different criteria that you will use to determine if your design was successful.

- i) _____
- ii) _____
- iii) _____
- iv) _____



Project Development



General Research:

1) Name the law that explains how CO2 dragsters are propelled.

2) If you double the pressure inside a CO2 canister what will happen to the volume?

3) Explain what happens when you puncture a CO2 canister?

4) Define the term Inertia.



5) What is Newtons Third Law of Motion?

6) Explain what is the difference between skin and fluid friction?



7) How do you determine the speed of the CO2 dragster.

Know the Limitations

Your dragster must be made within certain limitations and specifications. To produce it properly you must learn what these requirements are before beginning the design process. Find the overall sizes from the research folio and enter on the drawing below.

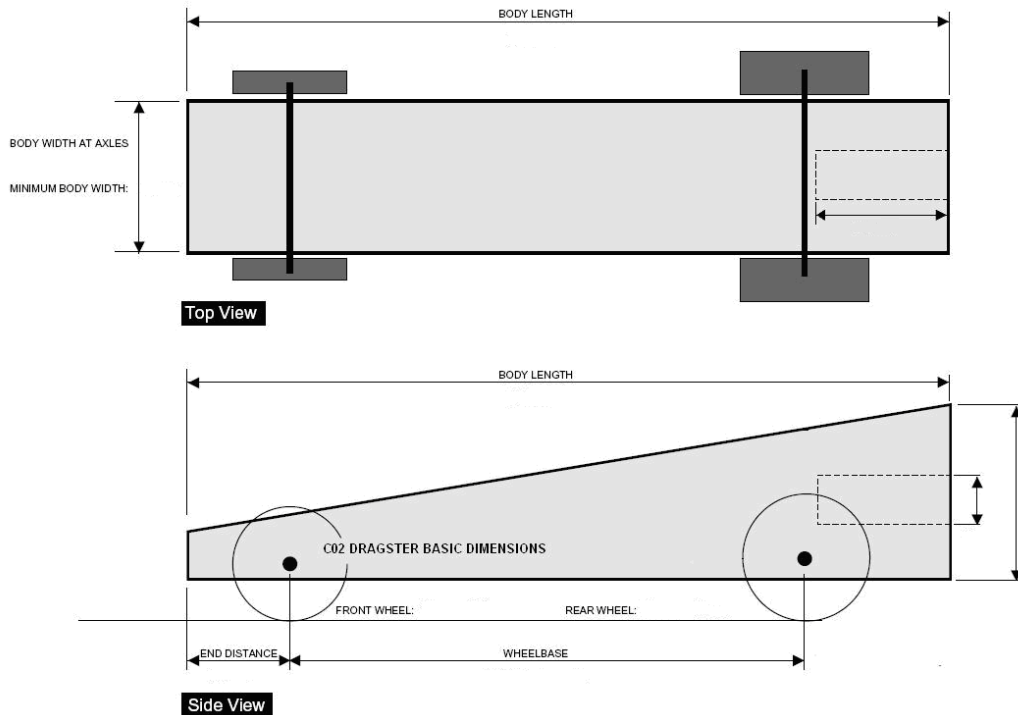

C) Idea Generation

Thumbnails

Fill out this the space below with as many thumbnail sketches as possible.

Have you filled in all the space?
There must be hundreds of different
body styles you could have.



Sketches

Look over your thumbnails and choose the best three ideas. Try to have three totally different designs rather than just one slightly changed. Draw a top and side view of each idea. Your sketches should be similar to the ones shown. Be sure to remember your production limitations. Refer to the drawings and list in your research folio. Use the next three pages for these top and side view drawings of each of your three designs.

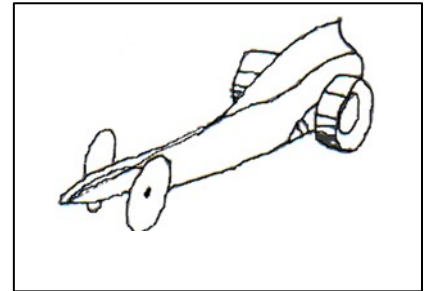

Example drawing of;

Top View

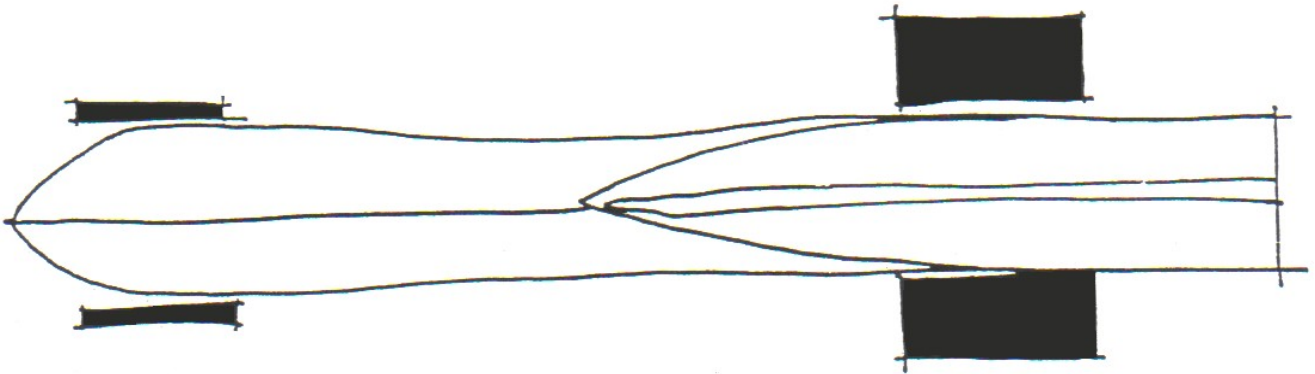

Side View

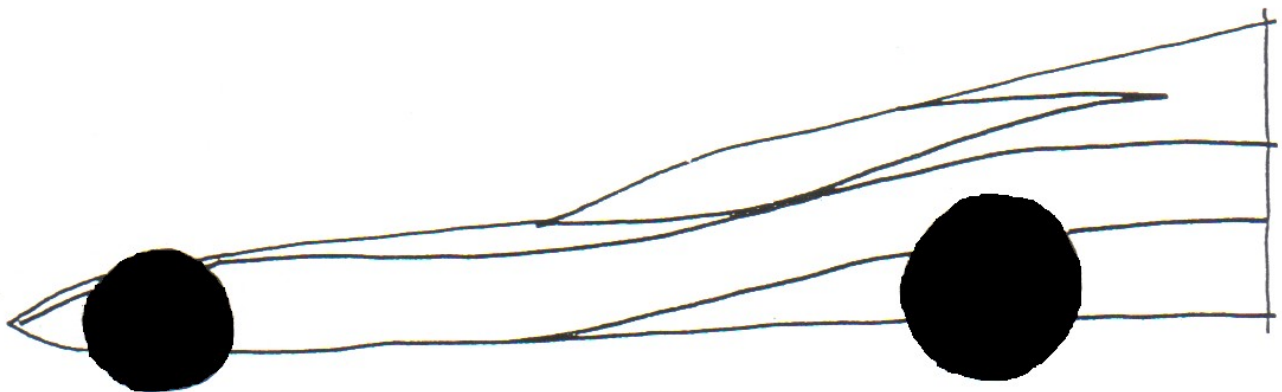

Now you do the same on the next three pages as shown here.

Sketch Design 1



Copy the thumbnail you are working from here.

Worth 1000.com
Be creative and try something different!

Top View

Side View

Evaluate

Good points

-
-

Bad points

-
-

Sketch Design 2

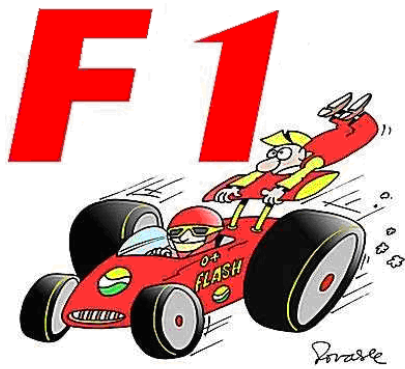

Top View

Copy the thumbnail you are working from here.

Side View

Evaluate

Good points

-
-

Bad points

-
-

Sketch Design 3

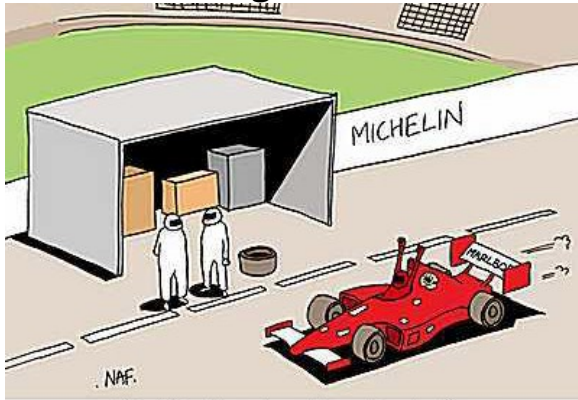

"It's not fair...Schumacher gets to practice a lap of honour before the race has even begun."

Copy the thumbnail you are working from here.

Top View

Side View

Evaluate

Good points

-
-

Bad points

-
-

Finished Drawing

Now you have reached the final drawing stage. This is the last step before making the model. Choose the best of the three detailed sketches. Carefully draw your chosen design on the dragster grid patterns provided on the opposite page. The drawings below are examples.

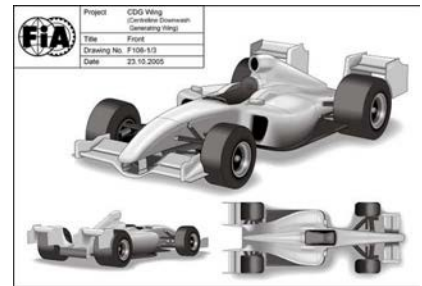

Top View

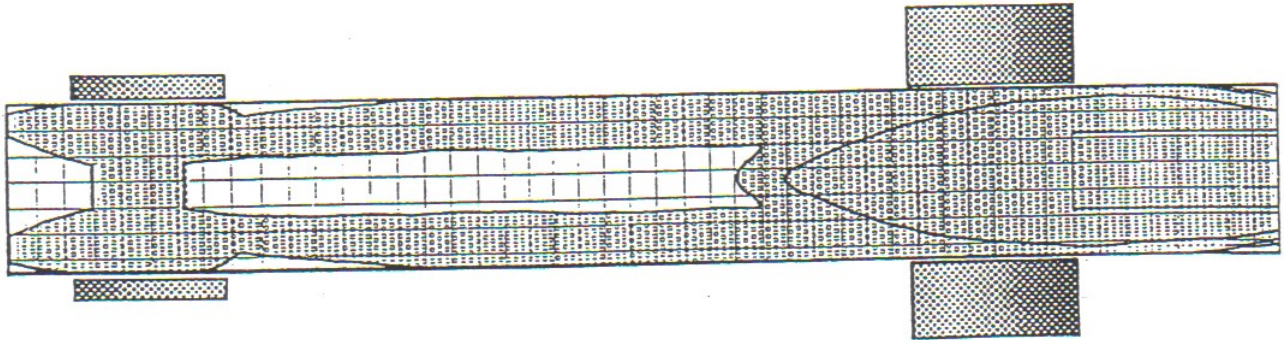

Side View

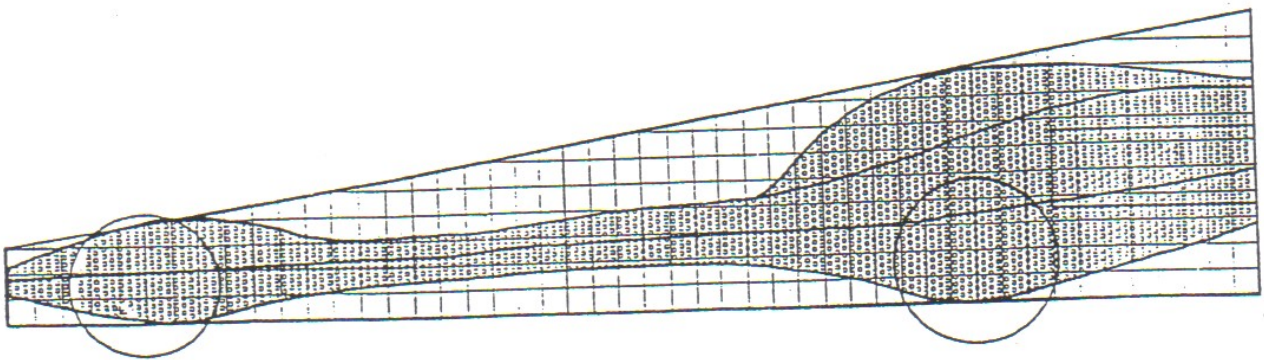

Checklist

- Is the front axle in the correct position?
- Is the rear axle in the correct position?
- Have you allowed enough room for the CO2 engine?

Finished Drawings

Do your finished drawings on these grids

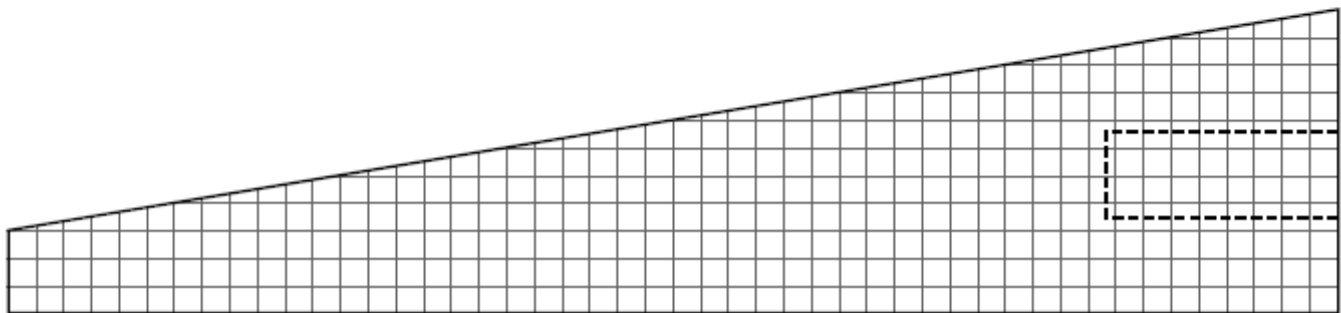
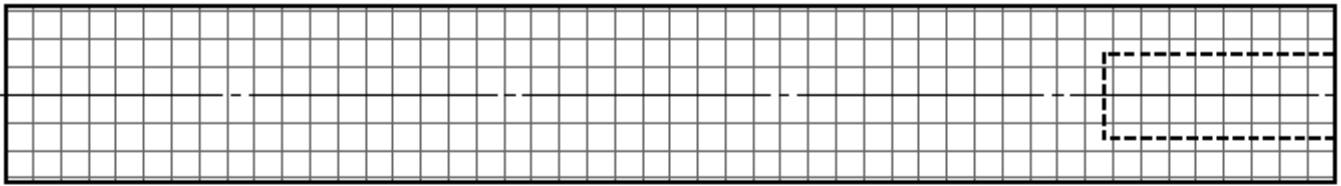

Carefully copy your design onto the final grid sheet.

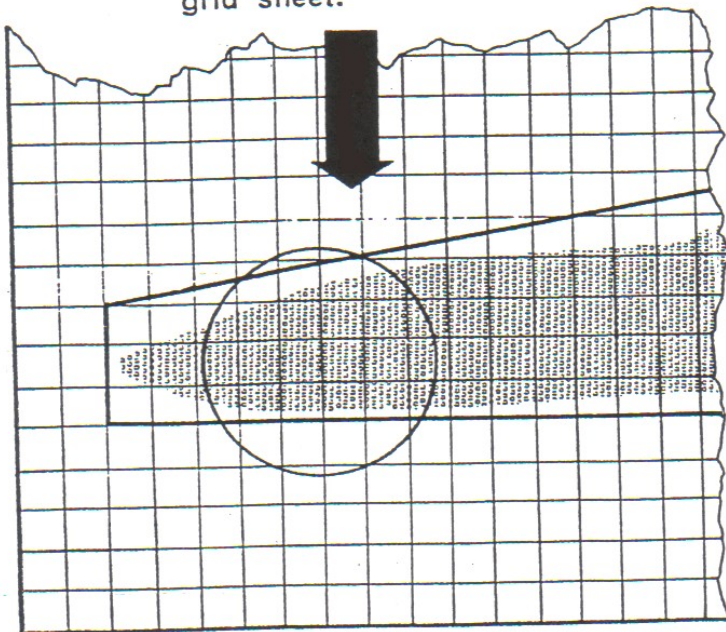

Note:

When you have finished drawing your dragster on the patterns above, transfer it to the full size grid sheet.

Draw the dragster to actual size within the listed specifications.

You must do these drawings very accurately because this will be used as a patterns for cutting and shaping the dragster body.



PROJECT REALIZATION

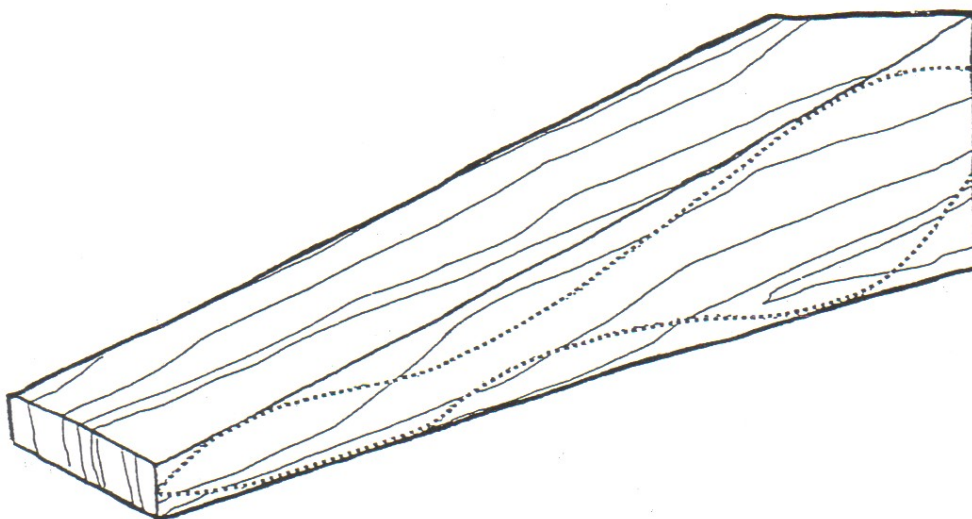
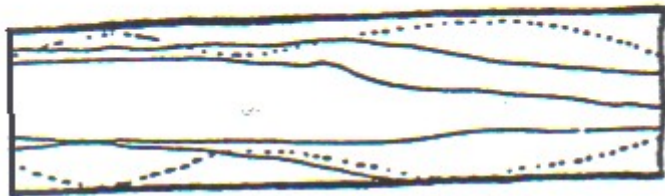
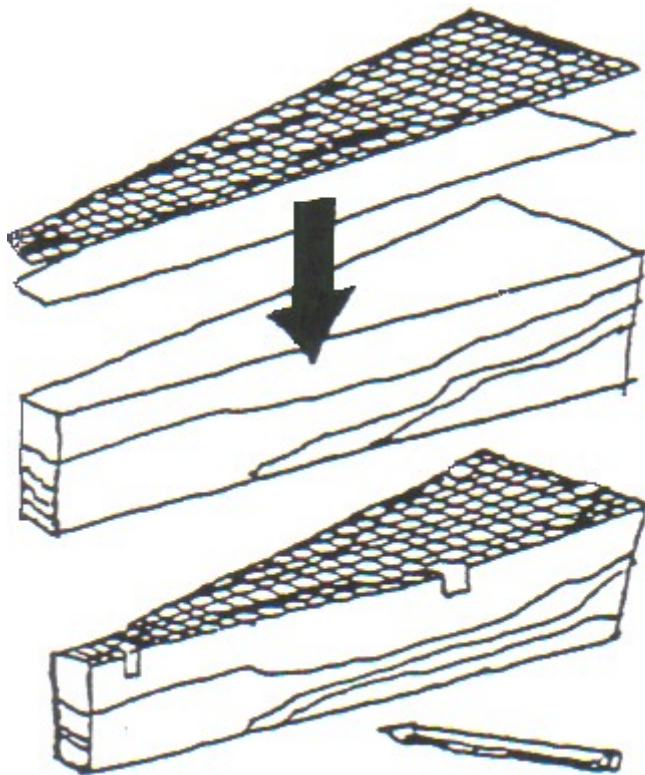

Layout

1. Place and tape the side view to the block of wood.
2. Trace and remove template pattern.
3. Mark axle locations
4. Place and tape the top view template pattern to the bottom of the block.
5. Trace around this pattern and then remove.

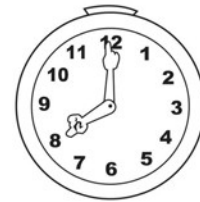

Take Your Time

Be sure to follow your patterns exactly. One major mistake can ruin the whole body design or cause your dragster to not meet specifications. Take pride in your work and try to make the best dragster in the class. Try to get the best grade possible for your craftsmanship.



Risk Management - Tools

List every tool and machine you will need to use in the construction of your job. Make sure you understand how to use each tool safely.

Name of tool/machine	What types of injury risks are possible	How is each risk of injury to be avoided

D) EVALUATION

To help you arrive at some conclusions about your work, carefully answer the following questions.

1. Did you do anything differently to your planned design?

2. List the difficulties that you encountered whilst making your design.

3. Complete the following table;

Good features of my design

Bad features of my design

Good features of my design	Bad features of my design

4. Indicate on the line below how successful you think you have been in achieving your goal as stated in the design brief?

**Very successful
successful**

Not very



5. What would you change about your design if you had to make it again?

6. How well did you do with the four criteria's for success that you set earlier?

CO2 Dragster Extension Questions

1. What is the purpose of the aero-foil behind the rear wheels?



2. Define the word aerodynamic.

3. Define the following terms:

Weight

Drag

Lift

Thrust



Forces

4. Fill in the missing forces that also operate on a car when it is in motion.



5. Fill out the following table

Force on Dragster	Advantages	Disadvantages
Lift		
Weight		
Thrust		

6. Why do designers try to minimise drag?

Research Question

1. What is a Land Speed Record vehicle? Explain how the design of their fuselage helps them to reach top speeds.
